



TEEBRO TOYOTA GVM SERVICE GUIDE

3900 & 4200kg GVM - **COIL**

70 SERIES

VDJLS
(VTA-048554)

J7LS & 1GD
(VAT-061677)

JMACX
Off Road Solutions



CUSTOMER HANDBOOK
Product Service & Maintenance Guide
FOR TEEBRO GVM VEHICLES

SSM 70 SERIES COIL GVM

Approval Number	Model
VTA-048 554	VDJ 70 Series coil
VTA-061 677	J7 70 Series coil

RECOMMENDED SERVICING:

All JMACX products should be serviced at regular intervals as per installation guidelines and original equipment manufacturer (OEM) standards. It is the responsibility of the Customer to maintain servicing of the Goods. Vehicle servicing standards are based on the normal driving use of the vehicle. Extreme driving conditions, increased load and stress on the vehicle will require more regular service intervals and major servicing. Failure to meet stated service requirements will void warranty coverage.

CONTENTS

70 SERIES 3900 & 4200 GVM - COIL	PAGE
CUSTOMER GVM HANDBOOK	1
COIL GVM SERVICE INFO	
AXLE GUIDE	10
DIFFERENTIAL GUIDE	12
CONTROL ARMS & TAIL SHAFT	13
TAIL SHAFT CONTINUED & PANHARD	14
COILS & AIR BAGS	15
BRAKES, FUEL & ABS/HANDBRAKE	16
CRADLE BOLTS & SWAY BAR LINKS	17
RUST PROOFING	19
ALPHA SHOCK SERVICE INFO	
HOW TO USE GUIDE	20

Thank you for choosing to use JMACX Off Road Solutions for your vehicle.

The JMACX team

TEEBRO TOYOTA

Congratulations on the purchase of your TEEBRO Toyota GVM Upgrade. This document contains details for the proper use and servicing of your vehicle. Due to specific differences among GVM upgrades, you may find that some information may not be applicable to your vehicle. For questions regarding your TEEBRO Toyota please contact the JMACX approved installation facility that completed the installation of your GVM upgrade or contact JMACX Head Office at sales@jmacx.com.au.

WARRANTY

TEEBRO GVM upgrades include standard manufacturer warranty. Normal driving use/conditions does not include driveline abuse, excessive power upgrades, excessive speed/driving style, larger than recommended tyres or excessive loads. Extreme driving conditions ie. Cape York / Simpson Desert travel will require a major service on the vehicle upon return of travel. Exposure of the Goods to aggressive corrosive environments such as salt water without sufficient cleaning and rock damage, will void the warranty. Where there is an alleged warranty issue, the Customer must obtain advice and approval in writing by JMACX prior to carrying out any repairs. Warranty does not cover product used in any type of racing or Motorsport competition, custom or modified applications under JMACX range of product, any illegal highway, marine, industrial or commercial use. JMACX does not accept liability for the voiding of a vehicle's manufacturer's warranty or part thereof subsequent to the fitting of the Goods to the Customer's vehicle.

1. Warranty only covers faulty components or faulty workmanship with respect to the purchased product.
2. This Warranty does not cover damage, fault, failure or malfunction of the Goods due to external causes including but not limited to accident, abuse, misuse, problems with electrical power, servicing not authorised by JMACX Off road Solutions, usage and/or storage and/or installation not in accordance with Product instructions, failure to perform required preventive maintenance, normal wear and tear, or any attempt by any other person other than JMACX Off road Solutions personnel or any person authorised by JMACX Off road Solutions, to adjust, repair or support the Goods and problems caused by use of parts and components not supplied by JMACX Off road Solutions.
3. JMACX Off road Solutions does not accept liability for the voiding of a vehicle's manufacturer's warranty or part thereof subsequent to the fitting of the Goods to the Customer's vehicle.
4. No warranty will be considered on any item that has been modified eg ground, drilled or welded without the written consent of JMACX Off road Solutions.
5. No product manufactured by JMACX or its subsidiary companies can be altered, modified or re-welded without the written consent of JMACX.
6. Oil seals and gaskets carry only 3 month warranty on vehicles being driven on road only
7. The warranties do not apply where the following may apply:
 - I. the incorrect grade of lubricant or insufficient amount of lubricant causing damage
 - II. the Goods are used beyond the expectations of the original vehicle or Goods' manufacturer
 - III. Acts of neglect or misuse are evident
 - IV. Product has been modified
 - V. Used in racing or competition conditions without prior consent of JMACX Off Road Solutions
 - VI. Used beyond the expectations of the original vehicle manufacture and or JMACX Off Road Solutions specifications.

SERVICING

8. It is the responsibility of the Customer to maintain servicing of the Goods. Vehicle servicing standards are based on the normal driving use of the vehicle. Extreme driving conditions, increased load and stress on the vehicle will require more regular service intervals and major servicing. Failure to meet stated service requirements will void warranty coverage. Normal driving use/conditions does not include driveline abuse, excessive power upgrades, excessive speed/driving style, larger than recommended tyres, excessive loads. Extreme driving conditions ie. Cape York / Simpson Desert travel will require a major service on the vehicle upon return of travel.
9. A full suspension check must be completed within 500km-1000km of suspension installation by a JMACX approved and certified installer, failure to do so will void warranty.
10. The 500-1000km mandatory suspension check must be completed at the facility the works were carried out at.
11. The Customer warrants to service the vehicle at recommended intervals.

GVM SUSPENSION UPGRADES

12. A full suspension check must be completed within 500km-1000km of suspension installation by a JMACX approved and certified installer, failure to do so will void warranty.
13. The 500-1000km mandatory suspension check must be completed at the facility the works were carried out at.
14. Removal of any JMACX Off Road solutions supplied component that forms part of the Federally approved GVM including computer re calibration will void any warranty.
15. JMACX Off Road Solutions GVM upgrades may have specific warranty terms. Refer to the Customer GVM handbook for details.

HIGH LIFT

16. When the lift on a vehicle exceeds 50mm we stipulate that low range should not be used in a scenario where the vehicle is travelling at a speed in excess of 40km p/hr due to driveline angles. OEM diff lockers are designed to disengage at speeds in excess of 40km p/hr therefore JMACX Off Road Solutions deems there to be no reason to be engaged in low range 4WD exceeding this speed.
17. If a customer has a reason to be above 40KM p/hr is low range, it is recommended to purchase at additional cost products that achieve this outcome that is not normally required. For example on a 4495kg GVM a Cardinal drive shaft can be added at an additional cost.

FITTING

18. Damage to products through fitment error by an installer other than JMACX Off Road Solutions HQ is not covered under warranty. Warranty may become void when product is installed in conjunction with anything other than genuine manufacturer or JMACX components.
19. Where required, JMACX recommend a wheel alignment after fitment of any new suspension component. Obtaining wheel alignments is the responsibility of the Customer.

BRAKE DOWNS

20. JMACX Off Road Solutions is not liable for any costs incurred to the customer in the event of a vehicle break down. This includes accomodation, towing fees, out of pocket expenses, emotional distress or loss of business expenses.

21. Any works, services or product fittings performed by a JMACX Off Road Solutions approved Facility or Installer that are deemed faulty are the responsibility of the Facility/Installer to rectify.

For full Warranty/Terms & Conditions information see the full JMACX Off Road Solutions Terms & Conditions available at www.jmacx.com.au

GVM & WEIGHT CARRYING SPECIFICATIONS

View your Gross Vehicle Mass (GVM) Specification on your Secure Vehicle Identification (SVI) sticker, located on your vehicle. For your GVM, front and rear axle load ratings and maximum towing mass see your GVM sticker located on your vehicle.

TYRE LOADING

View your Tyre Loading information on your Tyre Placard fitted to your vehicle. This includes your cold tyre inflation pressures and load capacity per axle.

ESSENTIAL MAINTENANCE & SERVICING

RECOMMENDED SERVICING:

All JMACX products should be serviced at regular intervals as per installation guidelines and original equipment manufacturer (OEM) standards. It is the responsibility of the Customer to maintain servicing of the Goods. Vehicle servicing standards are based on the normal driving use of the vehicle.

Extreme driving conditions, increased load and stress on the vehicle will require more regular service intervals and major servicing. Failure to meet stated service requirements will void warranty coverage.

WHEEL NUT CHECK:

All Vehicles with a GVM upgrade will require load rated wheels to be fitted to the vehicle. You MUST arrange for your wheel nuts to be torqued to specifications at 50-100km by a competent person.

500KM SERVICE CHECK:

After initial installation of any JMACX GVM the customer is required to have their vehicle checked at a JMACX authorised facility as soon as the vehicle has reach 500KM. If you do not return the vehicle to the JMACX facility that completed the original GVM works, an additional cost may occur as this service is part of the original fitting price.

This is a mandatory check to ensure all componentry is settled and compliant with all torque specifications. Failure to do this check will void all warranty.

* Please see Warranty terms for full advice.

This vehicle has been fitted with a JMACX rear differential housing.

APPLIES TO VEHICLES WITH FACTORY ELECTRIC LOCKERS

ENGAGE 4WD & LOCKER BEFORE AXLE OR DIFF REMOVAL

DO NOT DIS-ENGAGE UNTIL NEW AXLES ARE ARE FITTED THIS WILL STOP THE LOCKER DRIVER MECHANISM FALLING OUT.

ESSENTIAL MAINTENANCE & SERVICING

SERVICING CHECK LIST

PARTS TO CHECK (If applicable)	
All fastenings	
U-bolts	
Radius arm bolts	
After market wheel & wheel nuts	
Steering damper bolts	
Control arm bolts	
Panhard bolts	
Sway bar bolts	
Sway bar links	
Airbags- inspect for leaks	
Brake Boosters	
Brake lines	
Brake line fastenings and hoses	
Brake prop valve adjustment	
Exhaust mounting and flange bolts	
Shock mounting bolts	
Catch can bolts and hoses	
Fuel filter bolts and hoses	
Fuel tank front and rear mounting bolts	
Upgraded tie-rod mounting bolts	
Upgraded drag-link mounting bolts	

WARNINGS

⚠ **DIFFERENTIAL WARNING:**

For 70 series Landcruiser vehicles fitted with factory electric lockers the locker must be engaged and 4WD selected before axle and/or diff removal. Do not disengage until axles are re fitted. This will stop the locker driver mechanism from falling out. (Applies to front diff also)

⚠ **PRODUCT SAFETY WARNING:**

JMACX Offroad Solutions (JMACX) suspension products are intended to improve on and off road performance of your vehicle. Modifying your vehicle may result in vehicle handling differently than a factory equipped vehicle.

Extreme care must be used to prevent loss of control or vehicle rollover. Failure to drive your modified vehicle safely may result in serious injury or death. JMACX does not recommend the combined use of suspension lifts, body lifts or other lifting devices.

Always drive your modified vehicle at reduced speeds to ensure your ability to control your vehicle under all driving conditions.

⚠ **GVM AXLE OVERLOADING WARNING:**

Overloading of GVM on front or rear axle loads will void your warranty and may cause serious injury or death.



COIL CONVERSION CRADEL WARNING

Do not over tighten or re torque/tighten cradel bolts beyond specifications. SEE PAGE. 18 FOR TORQUE SPECS

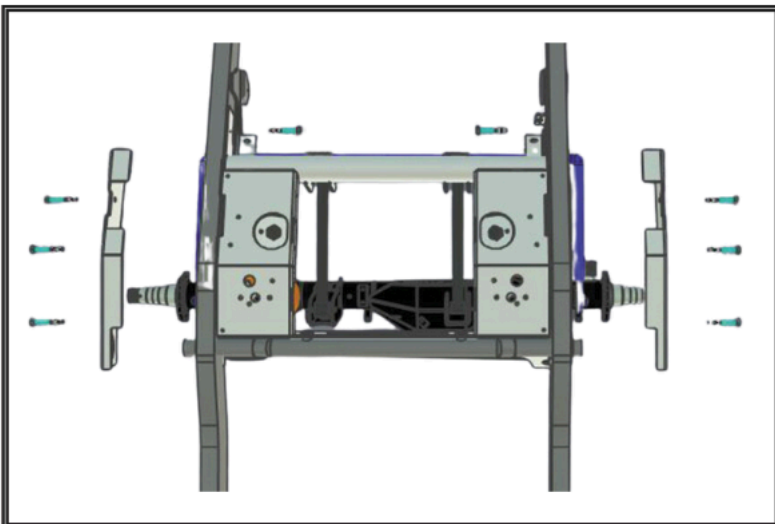

GVM & BTC LOADING

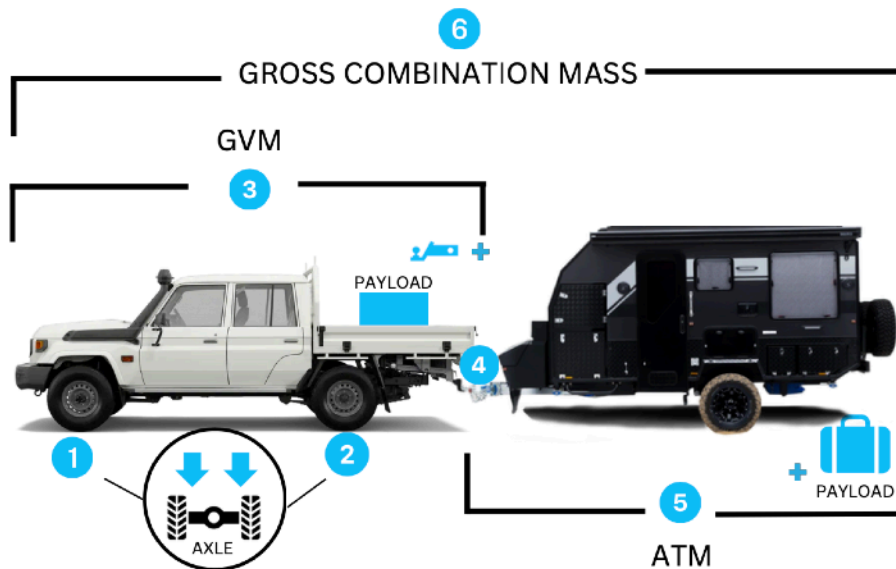

DEFINITIONS

- 1 & 2 GROSS VEHICLE AXLE MASS**
 The maximum load on either the Front or Rear axle resulting from the distribution of the GVM.

- 3 GROSS VEHICLE MASS (GVM)**
 GVM is the maximum allowable laden weight of a vehicle, as set by the manufacturer/GVM Provider. The vehicle, including its passengers, luggage, fuel, and weight on the tow ball can not exceed these figures.

- 4 TOW BALL WEIGHT**
 The proportion of the trailer weight that is applied to the rear of the tow vehicle. Most trailer mass is on wheels when you tow a caravan/trailer. However a small amount of the towing weight passes to the vehicle via the tow bar and ball. It is recommended to take your vehicle to a weigh bridge for an accurate calculation of tow ball weight.

- 5 AGGREGATED TRAILER MASS**
 The maximum that the trailer may weigh when its fully loaded, including tow ball weight.

- 6 GROSS COMBINATION MASS**
 The maximum total combined mass of a vehicle, its load including fuel, accessories, passengers, their gear and the total weight of any trailer it's towing.

 The maximum laden mass of the vehicle combination (tow vehicle and caravan) is not permitted to exceed the GCM rating. It is important to note that even if the tow vehicle and trailer are individually within their respective maximum ratings, the combination may not necessarily be within the GCM rating of the tow vehicle.

- 7 BRAKE TOW CAPACITY**
 The maximum weight that a vehicle will be able to tow when the trailer being towed is equipped with its own braking system, this includes ball weight.

GROSS VEHICLE MASS (GVM) - SPECIFIED BY THE VEHICLE MANUFACTURER/ GVM PROVIDER

GVM LOADING EXAMPLES

GVM TOWING



Example:

Use scales to measure front & rear axles with vehicle fully loaded then add Tow ball down weight.

Figures 1 & 2 **CAN NOT** be individually exceeded regardless of vehicle total weight.

GVM NOT TOWING

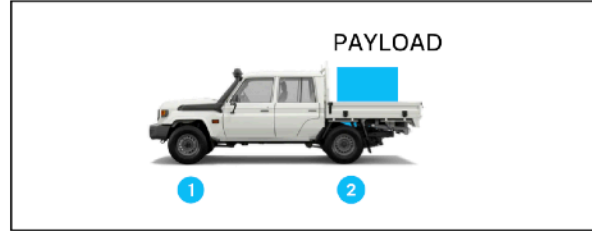

Example:

Use scales to measure front & rear axles with vehicle fully loaded.

Figures 1 & 2 **CAN NOT** be individually exceeded regardless of vehicle total weight.

GROSS COMBINATION MASS (GCM) - SPECIFIED BY THE VEHICLE MANUFACTURER/ GVM PROVIDER



MAXIMUM VEHICLE GCM

- *GVM type dependant
- *GCM conditions apply Pre registration
- *Post registered may vary as this is State & engineer dependant

BRAKE TOW CAPACITY (BTC) - SPECIFIED BY THE VEHICLE MANUFACTURER/ GVM PROVIDER



GVM & BTC LOADING

BTC Under Second Stage Manufacture = Post registration approved & State dependant

GVM	BTC	GCM	FRONT AXLE	REAR AXLE	APPROVALS
3900KG	3500KG	7400KG	1480KG	1550KG	Post rego/Engineer/State dependant
4200KG	3500KG	7700KG	2850KG	2850KG	Post rego/Engineer/State dependant

 **WARNING:** Overloading of either GVM on front or rear axle may result in serious injury or death, and will void all JMACX warranty.

PRODUCT INSTALLATION

△ Installation must be completed by a qualified service person.

The qualified service person has an obligation to obtain and follow the correct product installation specifications. JMACX will not be held liable for inadequate installation. Detailed installation instructions are provided to JMACX Authorised Installation Facilities or by request by email to sales@jmacx.com.au. These installation instructions are in addition to the original equipment manufacturer (OEM) manual.

PRE INSTALLATION NOTES:

- Refer to Original Equipment Manufacturer (OEM) service manual for model/year of vehicle for correct disassembly/reassembly procedures of all OEM components.
- Secure and properly block vehicle prior to installation of JMACX suspension products. Adhere to recommendations when replacement fasteners, retainers and keepers are called out in the OEM manual.
- Larger rim and tyre combinations may increase leverage on suspension, steering and related components. When selecting combinations larger than OEM, consider the additional stress you could be including on the OEM and related components.
- Post suspension system vehicles may experience driveline vibrations. Angles may require tuning, slip joints on shaft may require replacement, shafts may need to be lengthened or trued, and universal joints may need to be replaced.
- Secure and properly block vehicle prior to installation of JMACX suspension components.

COIL SPRINGS:

- Install new springs in the correct orientation and mounting position as the old springs. Be sure to re-install the original rubber insulators if fitted, or replace them if damaged.
- Please note that springs marked N/S are fitted to the near side (Passenger side), springs marked D/S are fitted to the drivers side. Variations to this can occur between left and right hand vehicles, or vehicles with modified weight distribution.
- Once installation is complete and the vehicle has settled if the vehicle seems to lean to a certain side, consider swapping the coils from side to side to resolve the issue.
- As some coil springs are of progressive rate design, the progressive portion (closer coils) should be fitted to the top.
- If in some cases the new coil spring installed may be shorter than the original spring ensure that the coil spring remains captive upon full articulation.

MODIFICATION CERTIFICATION: After fitment to any road registered vehicle, engineer modification certification is required as per law applicable in state of registration.

POST-INSTALLATION WARNINGS:

- Ensure all fasteners are checked and torqued to correct specifications. Check all steering components for clearance.
- Verify clearance between exhaust and brake lines, fuel lines, fuel tank, floor boards and wiring harness.
- Check steering components for clearance. Test and inspect brake system.
- Inspect brake hoses and breathers at full extension for adequate slack. Failure to carry out this check may result in component failure. If there is an issue with hose length the correct length hose should be sourced and replaced before completion of the vehicle. Longer replacement hoses, if needed should be purchased.
- All fasteners must be checked and torqued to specification after 500km. Fasteners and components should be inspected during regular servicing

DIFFERENTIAL: For vehicles fitted with JMACX rear (APPLIES TO FRONT DIFFS TOO) differential housing, you must engage 4wd and rear locker before removing axles.

APPLIES TO VEHICLES WITH FACTORY ELECTRIC LOCKERS

ENGAGE 4WD & LOCKER BEFORE AXLE OR DIFF REMOVAL

DO NOT DIS-ENGAGE UNTIL NEW AXLES ARE ARE FITTED
THIS WILL STOP THE LOCKER DRIVER MECHANISM FALLING OUT.

1. MUST use brass drift/punch to remove cones in conjunction with jacking bolts to remove drive plate. Drive plates are hardened steel, use of a hammer WILL cause fractures

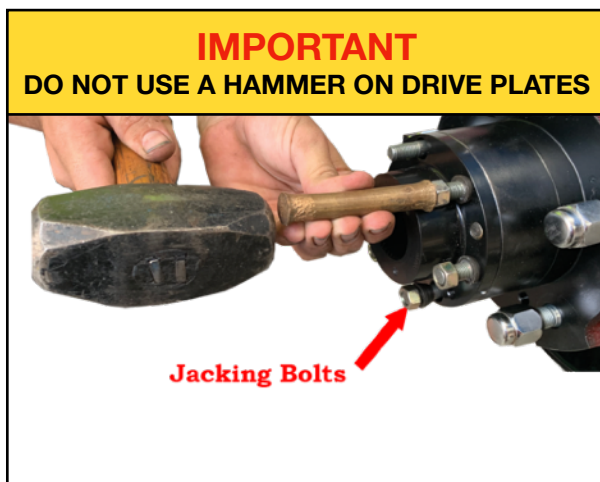

3. Insert JMACX axles into housing with circlip end facing outward on wheel hub end. Lightly grease the spline.

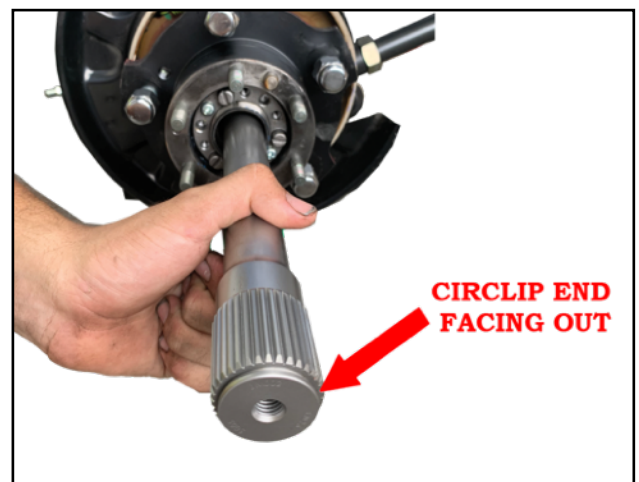

2. Seal is to be fitted flush with spindle face.

**RECOMMENDED TO ONLY USE
GENUINE TOYOTA AXLE SEALS.**

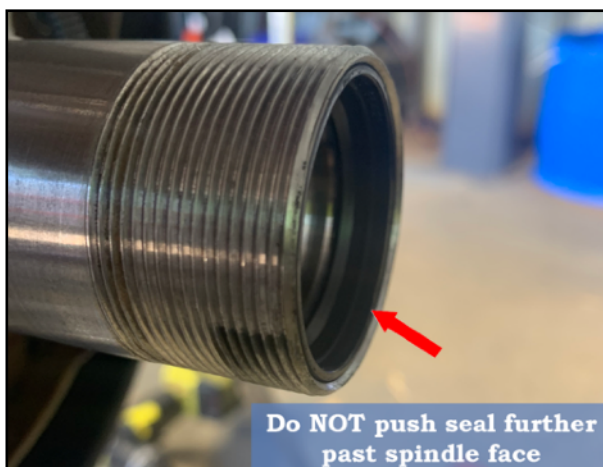

4. Fit JMACX drive plates to wheel hubs as per factory workshop manual for existing axle fitment.

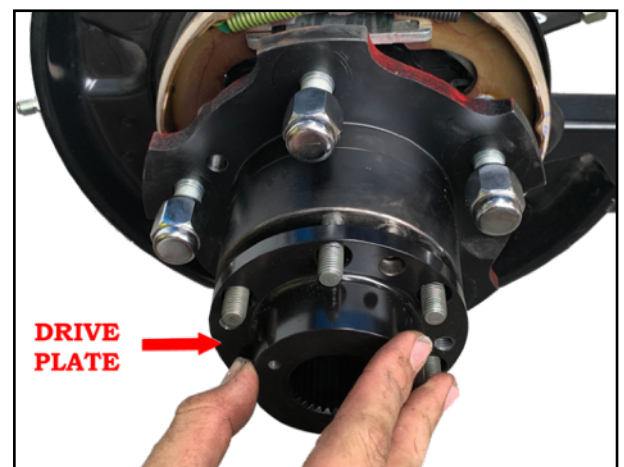

5. Fit Circlip to axle groove, ensuring circlip is firmly locked into position.



6. Apply a small amount of grease to blue end cap before fitting with 3 M6 bolts & o'ring.



WHEEL BEARING SERVICING

- Mandatory wheel bearing servicing at every 20,000km as per OEM book.

APPLIES TO VEHICLES WITH FACTORY ELECTRIC LOCKERS

ENGAGE 4WD & LOCKER BEFORE AXLE OR DIFF REMOVAL

**DO NOT DIS-ENGAGE UNTIL NEW AXLES ARE ARE FITTED
THIS WILL STOP THE LOCKER DRIVER MECHANISM FALLING OUT.**

1. Remove diff centre housing studs from factory diff housing and re install new JMACX housing using LOCTITE. ENSURE the 3 longer bolts are fitted in the correct position as per below image

2. Re assemble diff as per factory manual using factory axle seals and diff centre gasket. **NOT SUPPLIED** - Recommend to only use genuine Toyota axle seals.

Seal is to be fitted flush with spindle face.

IMPORTANT
DO NOT USE A RATTLE GUN TO REMOVE.
USE STUD REMOVAL TOOL

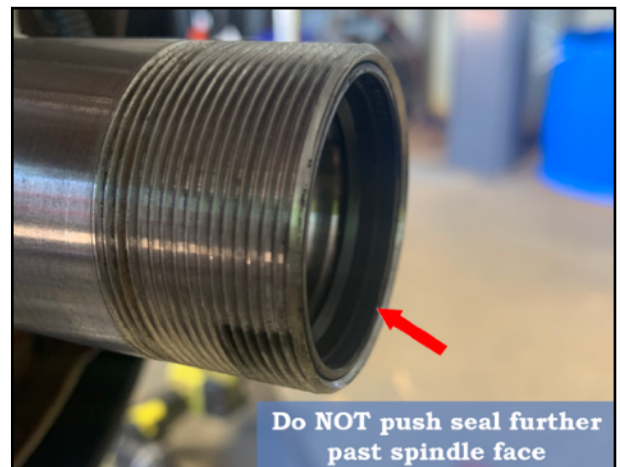

DIFFERENTIAL SERVICING DETAILS

INTERVALS	PART	MAINTENANCE REQUIRED
First 1,000 km	General	- Bolt check/re torque and oil change to completed at 1,000km.
First 1,000 km	Oil Change	Differential oil must be changed at 1,000km. (Oil change is an additional charge not covered by original fitment price)
Every 50,000 or after extreme use.	Oil Change	NOTE: Extreme conditions and /or extreme use will require more frequent servicing. (See below Warranty advice) Park on level ground. Fill with oil to plug level. Oil Type: 75W -90W oil as per original manufactures recommendation Oil capacity of Diff: 3.5 Ltrs (approx.)
Periodic Visual	General	Periodic visual inspection of the entire assembly is required. Check torque on all fasteners. Rotate hub assembly with drive flange and Axle removed to check hub bearings for smoothness. Check for leaks.
Every 20,000 km	Bearings	Mandatory wheel bearing servicing at 20,000km. Strip, inspect & repack bearings with high quality bearing grease. JMACX recommend to fit both a new 'Drive flange oil/ Axle seal' and a 'Drive flange to hub o-ring'.
Every 100,000 km	Bearings	REPLACE bearing - SEVERE DUTY/USE MAY REQUIRE REPLACEMENT SOONER

Refer to JMACX Warranty terms for advice on "Normal use" of the upgraded diff housing.

WARRANTY

26. Normal driving use/conditions DOES NOT include: driveline abuse, excessive power upgrades, excessive speed/driving style, larger than recommended tyres, excessive loads. Extreme driving conditions ie. Cape York/Simpson desert travel will require a major service on the vehicle upon return of the travel.

1. Adjust upper and lower control arm for drive shaft/pinion angle. (Angle to be parallel to transfer pinions angle). Use of an angle finder recommended.



NOTE: All bolts installed are to point towards the centre of the vehicle. (To ensure clearance of coil springs)

Drive shaft angles are required to be set with a loaded vehicle. It is recommended to have the vehicle on the ground at normal operating height.

Tail shaft yoke and gear box yoke should be at parallel to each other.

See below link for info:

DRIVE SHAFT VIDEO

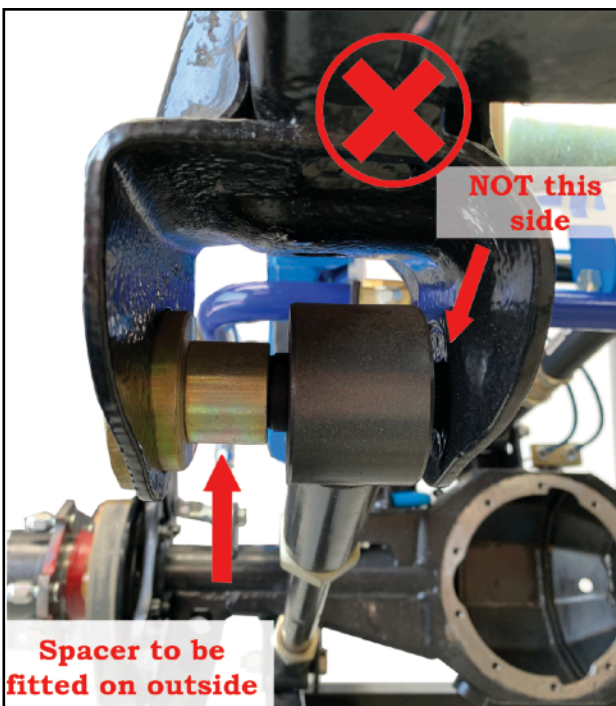

5. Check that all locking nuts on the adjustable control arms are locked up and check tightening again after all adjustments are complete.

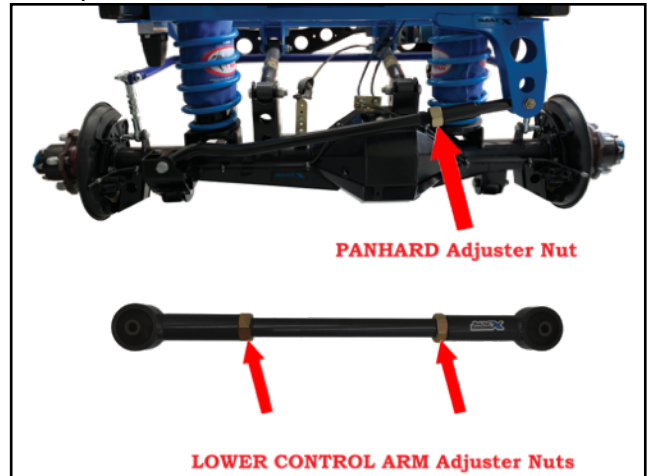

REAR UPPER & LOWER CONTROL ARMS

Torque specs:

18mm Bolts = 240 - 250 Ft-Lb Dry

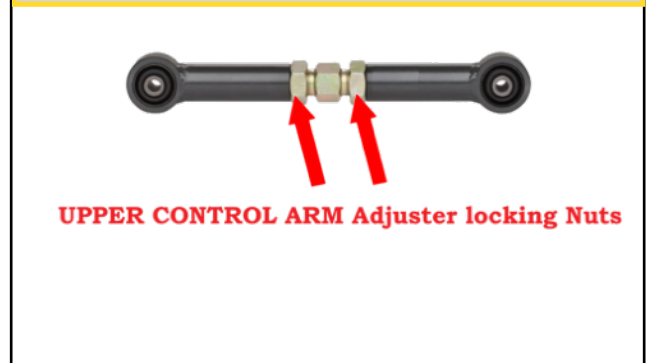

TAILSHAFT

1. Control arms are to be adjusted to achieve correct tail shaft clearance.

2. With vehicle on hoist allow rear suspension to fully drop. Adjust control arms to achieve minimum 10mm clearance in tail shaft slip joint.

3. It is recommended to remove tail shaft slip joint grease nipple to allow slip yoke maximum travel for measure. **Installer must grease uni joints and spline on fitment of tail shaft.**

4. Double check pinion angle.

5. Test drive vehicle & complete wheel ramp test to ensure correct fitment & clearance.

SEE NEXT PAGE FOR TAIL SHAFT MAINTENANCE DETAILS.

TAILSHAFT MAINTENANCE

- Grease uni joints & spline on install and every 20,000km
- Slip joint must be separated in order to grease
- Mark slip joints spline position before removing
- Make sure slip joint orientation is exact after greasing.

PANHARD

1. Install panhard using 2ea M16 bolts supplied. The DOME head bolt is to be located to the front side of Panhard as shown in photo below.

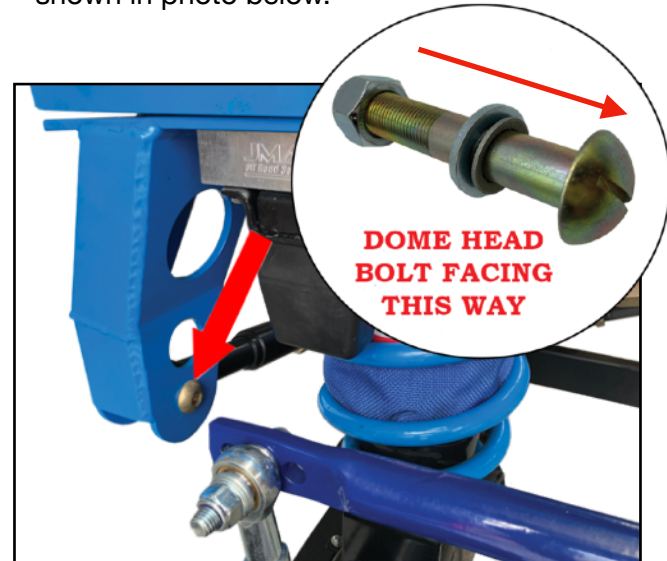

2. Lower the vehicle to the ground. The Panhard is designed to be set so the rear axle is centralised to vehicle right to left. Panhard may need to be over adjusted to allow once a tray/canopy is fitted.

3. Bolts must be tightened when wheels are not on a hoist, must be on ground.

Any bushes tightened on a hoist may tear from incorrect installation.

PANHARD TORQUE SPECS

REAR UPPER & LOWER CONTROL ARMS

Torque specs:

18mm Bolts = 240 - 250 Ft-Lb Dry

HEX HEAD BOLT

PANHARD

Torque specs:

170 FT-LB Lubed

PANHARD

Torque specs:

170 FT-LB Lubed

COIL INSTALLATION

1. Install bump stop supplied with 2 x M8 Bolts. (Only where airbags are not used)

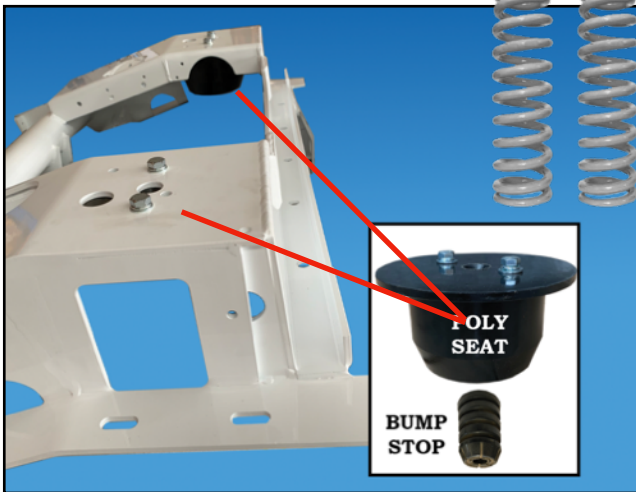

2. Install coil springs as marked Drivers Side and Passengers side. Make sure coil is rotated into locator tab.
3. Install shock absorbers as per manufacturers supplied specifications.

AIRBAG INSTALLATION

1. Position your inflation valves in a location that is protected from road damage. Drill a 5/16" hole & install the air inflation valve using two 5/16" stainless steel washers as support where required.

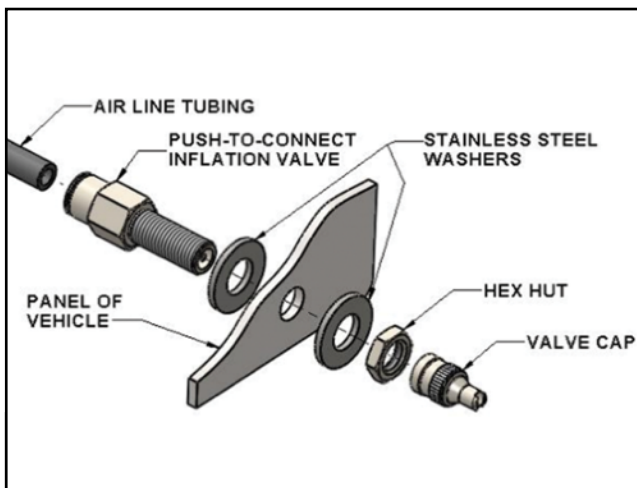

****Place protector spacer with cone to the top**

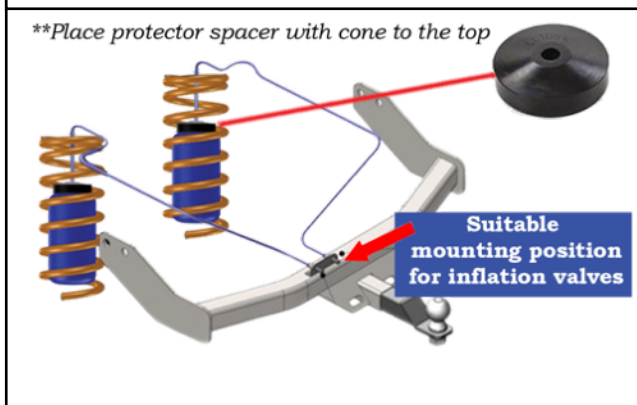

2. Cut air line tube to length to suit the chosen route away from direct heat & sharp edges. The protector tube is pulled back later to prepare the protected line.
DO NOT CONNECT OR SECURE THE AIR LINE AT THIS POINT.



3. Install the airbag into the coil with air inlet to the top. Re install coil to vehicle. Connect the airline tubing by inserting one end into the airbag air fitting, the other end into the installed inflation valve.

4. Inflate airbag to maximum allowed pressure and check for leaks using soapy water spray.



IMPORTANT

Check airbag is NOT in contact with any sharp edges or too close to exhaust in all vehicle travel Heights. Ensure airbag lines are NOT affected by TRAY, TANKS, DRAWERS ETC.

It is recommended to inflate Air bags with 5 PSI minimum when NOT in use. This will ensure that the bag is not pinched in the coils.

1. Fit factory diff bracket line T-piece to bracket located on top of housing.

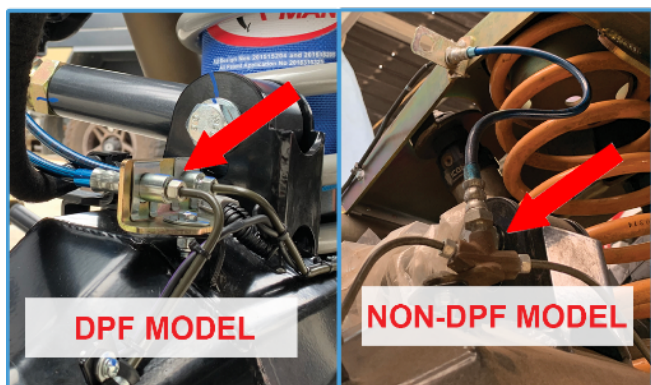

2. Fit Hard brake lines supplied either DPF or Non DPF variant.
Lines must be fitted with supplied line clips
NOT ZIP TIES

3. Brake lines will require bending to fit snug against diff housing. Fit p/clips to brake lines with M8 x 20mm bolts.

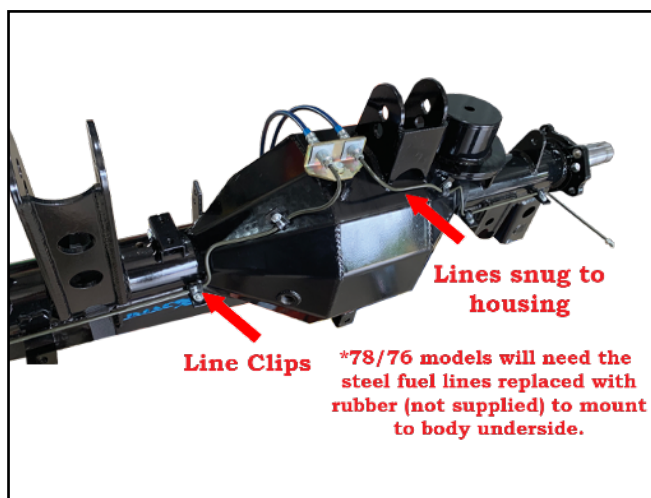

4. Remove all brackets from ABS cable & attach along brake lines securely with zip ties.
(Ensure care is taken so as to not damage ABS lines)

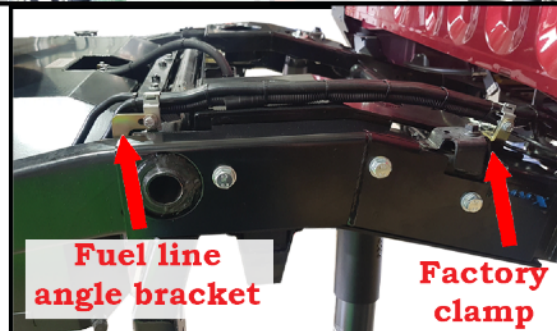

5. Bleed brake assembly as per vehicle manufactures specifications. Check ABS is working correctly.

6. Check:
- system for leaks
 - lines are secured correctly
 - brake proportioning valve adjustment (as per vehicle manufactures specifications.)
 - brake pressure test recommended

7. Make sure all brake lines on diff will not foul under operating conditions.

HANDBRAKE

8. Fit factory hand brake cable. Install hand brake tabs to extend at cable ends & use 2ea x M8 bolts supplied.

9. On an older vehicle, if the hand brake cable need more adjustment it may be necessary to cut the handbrake tab in half and re-drill the 8.5mm hole to get more adjustment. (LHS)

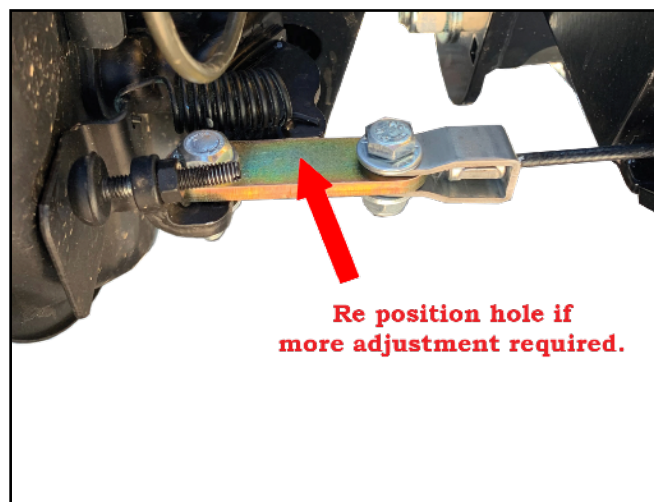

CRADLE BOLTS

NOTE: Do NOT over tighten or re-tension/tighten beyond specifications. See below three step torque guide.

Cradle Bolts	Step 1	Step 2	Step 3
Torque in Ft/Lbs	30	45	60

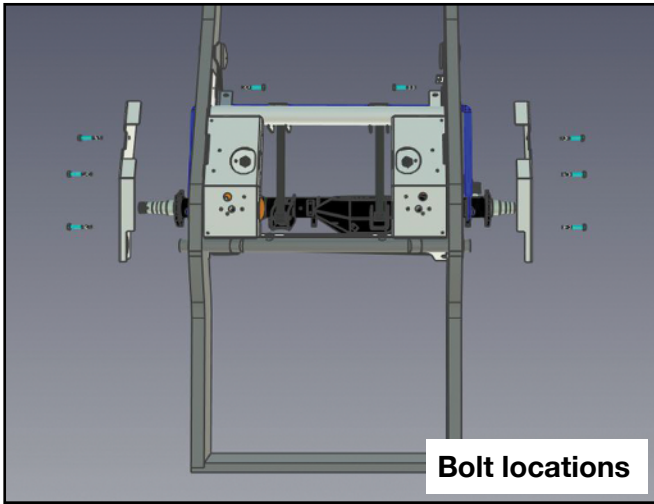
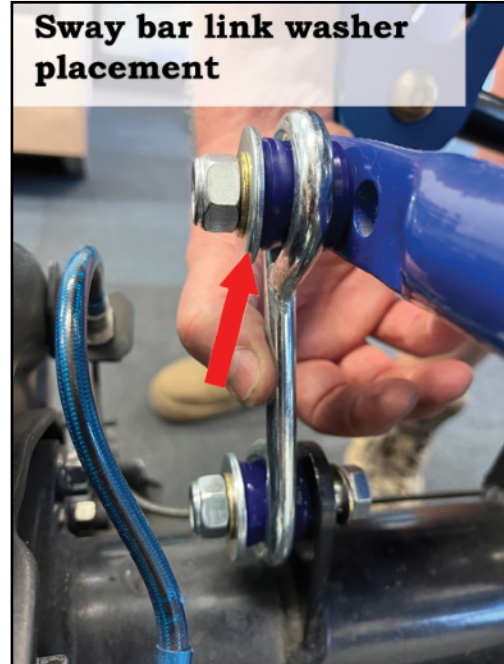

FIGURE 8 SWAY BAR LINKS

Install/replace sway bar links with bolts facing this way.

NOTE: High Lifts & excessive wheel travel off road can damage sway bar links



JMACX SWAY BAR LINKS

SEE NEXT PAGE



JMACX SWAY BAR LINKS

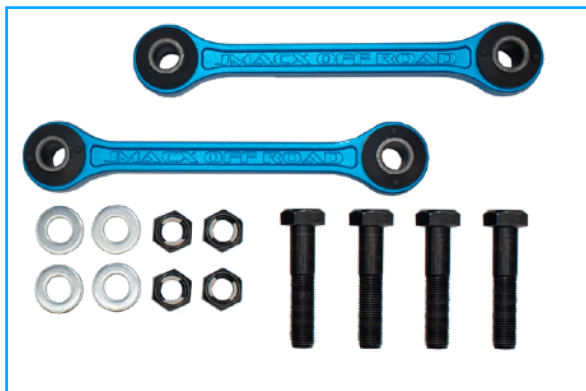

KIT INCLUDES:

- 2 x SWAY BAR LINKS
- 4 x M12 BOLTS
- 4 x NYLOCK NUTS
- 4 x WASHERS

1. Ensure vehicle wheels are chocked and in a safe position to work on. Proper safety procedures must be followed, and care taken.
 2. Remove the OE sway bar link pin assembly from sway bar and diff mount.
 3. Install the JMACX links with bolts and washers with reference to the bolt orientation shown in figure 2. M12 nuts are to be tightened to 90 NM
- Always use new hardware if supplied.
 - Tighten all fittings with the vehicle at ride height on the ground.
 - For noise and friction free operation, carry out periodic inspections.
 - WARRANTY: 12 months

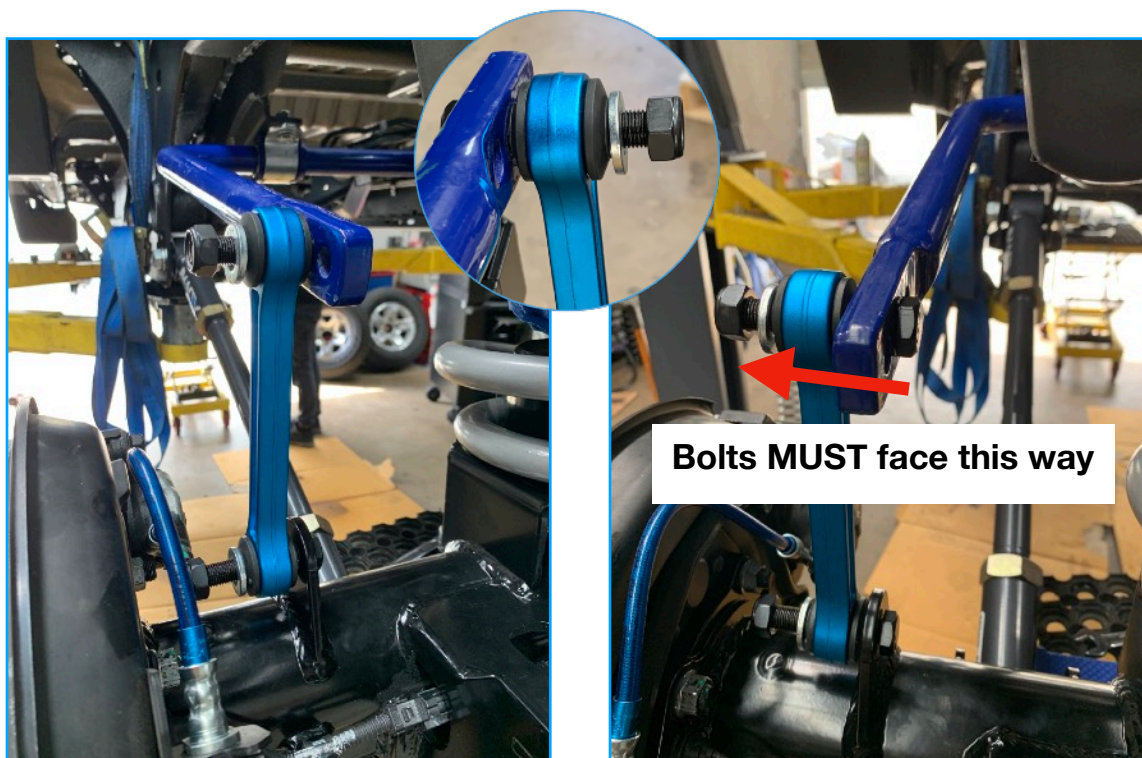

All torque specifications are to be checked after 1000km of travel.
Please drive carefully to get used to the new handling characteristics.
JMACX does not take responsibility for incorrect fitment or misuse of this product.

RUST PROOFING

It is the customers responsibility to rust proof and treat the vehicle. JMACX highly recommends treating the chassis with a suitable rust proofing product. It is not the Installer or JMACX responsibility. This service can be arranged at an additional cost.



ALPHA

For all ALPHA electric and manual instructions please see the separate 'ALPHA Manual & Electric' install guides.

Below are the QR quick links:



Manual Install Guide



Electric Install Guide

SHOCK CARE GUIDE ALSO AVAILABLE



MANUAL 'HOW TO USE' GUIDE AVAILABLE

ALPHA MANUAL SHOCK SETTING GUIDE

EASY TO USE

Thank you for purchasing ALPHA 2.5 remote reservoir manual shock absorbers. Your shocks are equipped with an adjustable dial on the top of the reservoir body, this adjusts the compression, making them one of the easiest adjustable shocks on the market.

HOW TO ADJUST

Fine tuning your shocks is purely personal preference. What feels great for one person, won't necessarily feel right for another. On the top of the reservoir body you will locate a dial. This dial is operated via a clockwise or an anti-clockwise motion.

The ALPHA 2.5 shocks are supplied on factory settings with the dial set at all the way left at zero clicks. To start adjusting you will need to turn the dial in a clockwise direction.

- It is recommended you start at a base rate of 4 clicks clockwise from the factory setting on all shocks. This is a starting point, from here it is recommended to drive the vehicle and readjust as necessary.
- The rear pair of shocks can be set to a different setting to the fronts. This is completely acceptable and would be recommended when carrying a heavier than normal load in the rear of your vehicle.

IMPORTANT: When adjusting the dial, they should be evenly rotated by hand, but tools or force are required to do so.

REBUILD

These shock absorbers are 100% rebuildable and should only be rebuilt by a JMACX approved shock service centre. Alternatively the shocks can be posted to JMACX HQ for servicing.

SHOCK SPECIFIC WARRANTY

The ALPHA shock has a warranty period of 2 years or 50,000km, whichever comes first. There is a warranty of 12 months on the electronic components. Warranty is not transferable and only applies to the original purchaser. This is in accord with the JMACX standard warranty found at www.jmacx.com.au. Any claims on defective goods need to be raised with JMACX Offroad Solutions or an authorised inspection facility. Exposure to aggressive corrosion elements like lithium, to wash after with water contact or rock damage will void the warranty.

SETTINGS

Use the below table to record your preferred settings and keep handy for future reference.

Date	Driving Type	FRONT Adjuster clicks	REAR Adjuster clicks
Region:			
Vehicle:			
Load(s):			
Other:			

JMACX.COM.AU | PH 01 940 2901 | SALES@JMACX.COM.AU

JMACX
AUSTRALIAN MADE & MANUFACTURED
THE J.M.A.C.H. MORE SHOCK ABSORBERS

JMACX OFFROAD SOLUTIONS
PO BOX 2222
MILTON, QLD 4053
SALES@JMACX.COM.AU
WWW.JMACX.COM.AU
f @ in d